



DESIGNED AND DEVELOPED IN THE NETHERLANDS 

CORDLESS LI-ION SCREWDRIVER

3.6V - 1.3AH CDM1124

Specifications

Mains voltage (charger)	100-240V~, 50/60Hz
Power input	3.6V-1.3Ah
Max. torque	3Nm
No load speed	200/min.
Charging time	3-5 hours



Features

- Cordless, Li-Ion technology
- Spindle lock
- LED work light
- Magnetic bitholder 1/4"
- Storage case

Includes 25pcs bit set - Charger adapter

CORDLESS LI-ION DRILL

12V - 1.5AH CDM1118

Specifications

Mains voltage (charger)	100-240V~, 50/60Hz
Power input	12V-1.5Ah
Max. torque (hard)	20Nm
No load speed position I	0-350/min.
No load speed position II	0-1.300/min.
Number of torque positions	17+1
Charging time	1 hour



Features

- Cordless, Li-Ion technology
- LED work light
- Single sleeve chuck 1.0-10mm
- Adjustable torque settings
- Two mechanical speed settings
- Variable electronic speed control
- Storage case

Includes Li-Ion battery (12V-1.5Ah) - 2 Double sided 50mm bits (S2) - Charger
Optional Accessories Bit set CDA1035 - Battery CDA1085

CORDLESS LI-ION DRILL

12V - 1.5AH CDM1119

Specifications

Mains voltage (charger)	100-240V~, 50/60Hz
Power input	12V-1.5Ah
Max. torque (hard)	20Nm
No load speed position I	0-350/min.
No load speed position II	0-1.300/min.
Number of torque positions	17+1
Charging time	1 hour



Features

- Cordless, Li-Ion technology
- 2 Batteries
- LED work light
- Single sleeve chuck 1.0-10mm
- Adjustable torque settings
- Two mechanical speed settings
- Variable electronic speed control
- Storage case

Includes 2 Li-Ion batteries (12V-1.5Ah) - 2 Double sided 50mm bits (S2) -
Charger
Optional Accessories Bit set CDA1035 - Battery CDA1085

CORDLESS LI-ION DRILL

18V - 1.5AH CDM1120

Specifications

Mains voltage (charger)	100-240V~, 50/60Hz
Power input	18V-1.5Ah
Max. torque (hard)	32Nm
No load speed position I	0-350/min.
No load speed position II	0-1.300/min.
Number of torque positions	17+1
Charging time	1 hour



Features

- Cordless, Li-Ion technology
- 2 Batteries
- LED work light
- Single sleeve chuck 1.5-13mm
- Adjustable torque settings
- Two mechanical speed settings
- Variable electronic speed control
- Storage case

Includes 2 Li-Ion batteries (18V-1.5Ah) - 2 Double sided 50mm bits (S2) -
Charger
Optional Accessories Bit set CDA1035 - Battery CDA1087

CORDLESS LI-ION IMPACT WRENCH

18V - 4.0AH CDM1127

Specifications

Mains voltage (charger)	100-240V~, 50/60Hz
Power input	18V-4.0Ah
Max torque	380Nm
No load speed	0-2.300/min.
Charging time	3-5 hours



Features

- Cordless, Li-Ion technology
- 1/2" square drive shaft
- LED work light
- Variable electronic speed
- Soft grip
- Storage case

Includes Li-Ion battery (18V-4.0Ah) - Socket 19mm - Socket 21mm - Charger

IMPACT DRILL

550W PDM1051

Specifications

Mains voltage	220-240V~, 50Hz
Power input	550W
No load speed	0-3.000/min.
No load impact rate	0-48.000/min.
Chuck capacity	1.5-13mm



Features

- Double function
(drilling and impact drilling)
- Depth limiter
- Variable electronic speed control
- Lock-on switch
- 3m rubber cable

Includes Side handle - Depth limiter - Chuck key

IMPACT DRILL

800W PDM1052

Specifications

Mains voltage	230V~, 50Hz
Power input	800W
No load speed	0-3.000/min.
No load impact rate	0-48.000/min.
Chuck capacity	1.5-13mm



Features

- Double function (drilling and impact drilling)
- Depth limiter
- Variable electronic speed control
- Lock-on switch
- 3m rubber cable

Includes Side handle - Depth limiter - Chuck key

ROTARY HAMMER

850W HDM1028

Specifications

Mains voltage	230-240V~, 50/60Hz
Power input	850W
No load speed	900/min.
No load impact rate	4.000/min.
Impact energy	4.5 Joule



Features

- 3 Functions (drilling, hammer drilling, chiseling)
- Universal SDS-plus toolholder
- 3m cable
- Storage case

Includes Side handle - Dust cover - Grease tube - Depth gauge - 3 SDS concrete drills (8mm, 10mm, 12mm) - Chisel pointed (250mm) - Chisel flat (250mm) - Grease cover - Wrench

ROTARY HAMMER

1500W HDM1037

Specifications

Mains voltage	230V~, 50Hz
Power input	1.500W
No load speed	0-950/min.
No load impact rate	0-4.400/min.
Impact energy	6.0 Joule



Features

- 4 Functions (drilling, hammer drilling, free rotation chiseling, chiseling)
- Universal SDS-plus toolholder
- Variable electronic speed control
- 3m cable
- Storage case

Includes Side handle - Dust cover - Grease tube - Depth gauge - 3 SDS concrete drills (8mm, 10mm, 12mm) - Chisel pointed (250mm) - Chisel flat (250mm) - Grease cover - Wrench

ANGLE GRINDER

500W - 115MM AGM1086

Specifications

Mains voltage	230V~, 50Hz
Power input	500W
No load speed	11.000/min.
Disc diameter	115mm
Spindle	M14



Features

- Lock-on switch
- Spindle lock
- Adjustable open safety guard
- Electronic restart protection
- 3m cable

Includes Side handle - Wrench - Hexagonal key
Optional Accessories Diamond disc 115mm AGA1018 (open) - AGA1020 (closed)

ANGLE GRINDER

750W - 115MM AGM1060S

Specifications

Mains voltage	230-240V~, 50Hz
Power input	750W
No load speed	12.000/min.
Disc diameter	115mm
Spindle	M14



Features

- Paddle switch
- 3 Side handle positions
- Spindle lock
- Adjustable open safety guard with quick release
- 3m rubber cable

Includes Side handle - Wrench
Optional Accessories Diamond disc 115mm AGA1018 (open) - AGA1020 (closed)

ANGLE GRINDER

850W - 125MM AGM1087

Specifications

Mains voltage	230V~, 50Hz
Power input	850W
No load speed	11.000/min.
Disc diameter	125mm
Spindle	M14



Features

- Lock-on switch
- Spindle lock
- Adjustable open safety guard
- Electronic restart protection
- 3m cable

Includes Side handle - Wrench - Hexagonal key
Optional Accessories Diamond disc 115mm AGA1019 (open) - AGA1021 (closed)

ANGLE GRINDER

900W - 125MM AGM1061S

Specifications

Mains voltage	230-240V~, 50Hz
Power input	900W
No load speed	12.000/min.
Disc diameter	125mm
Spindle	M14



Features

- Paddle switch
- 3 Side handle positions
- Spindle lock
- Adjustable open safety guard with quick release
- 3m rubber cable

Includes Side handle - Wrench
Optional Accessories Diamond disc 115mm AGA1019 (open) - AGA1021 (closed)

ANGLE GRINDER

2500W - 230MM AGM1088

Specifications

Mains voltage	230-240V~, 50Hz
Power input	2.500W
No load speed	6.500/min.
Disc diameter	230mm
Spindle	M14



Features

- Lock-off safety switch
- Spindle lock
- Adjustable open safety guard
- Soft start
- 3 Side handle positions
- 3m rubber cable

Includes Side handle - Wrench - Hexagonal key

CORDLESS LI-ION JIG SAW

12V - 1.5AH JSM1026

Specifications

Mains voltage (charger)	100-240V~, 50/60Hz
Power input	12V-1.5Ah
No load speed	2.100/min.
Charging time	3-5 hours



Features

- Cordless, Li-Ion technology
- Quick release blade holder
- Universal, suitable for T & U shank blades
- Soft grip
- Storage case

Includes Li-Ion battery (12V-1.5Ah) - Saw blade (wood) - Saw blade (metal) - Charger
Optional Accessories Battery CDA1094 - Jig saw blades 10pcs JSA1004

JIG SAW

570W JSM1023

Specifications

Mains voltage	230V~, 50Hz
Input power	570W
No load speed	500-3.000/min.
Bevel adjustment	0-45°
Saw stroke	18mm
Saw capacity wood max.	70mm
Saw capacity steel max.	6mm



Features

- Lock-on switch
- Electronic variable speed
- 4 Pendulum positions
- Variable mitre cut adjustment to 45°
- Dust extraction outlet
- 3m cable

Includes Parallel guide - Hexagonal key - Vacuum cleaner adapter - 4 T-shank saw blades
Optional Accessories Jig saw blades 10pcs JSA1004

JIG SAW

710W JSM1014

Specifications

Mains voltage	230V~, 50Hz
Input power	710W
No load speed	800-3.000/min.
Bevel adjustment	0-45°
Saw stroke	20mm
Saw capacity wood max.	110mm
Saw capacity steel max.	10mm

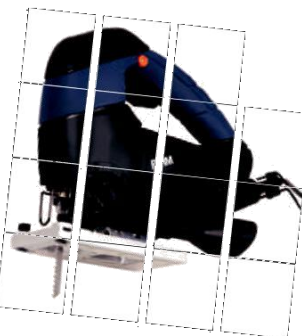

Features

- Lock-on switch
- Electronic variable speed
- 4 Pendulum positions
- Variable mitre cut adjustment to 45°
- Dust extraction outlet
- 3m cable

Includes Parallel guide - Hexagonal key - Vacuum cleaner adapter - 3 T-shank saw blades
Optional Accessories Jig saw blades 10pcs JSA1004

RECIPROCATING SAW

710W RSM1019

Specifications

Mains voltage	230-240V~, 50Hz
Input power	710W
No load speed	0-2.800/min.
Saw stroke	20mm

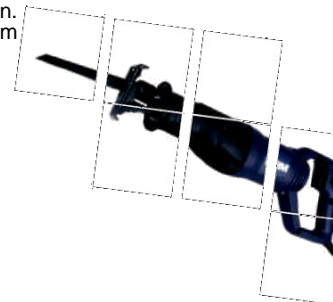

Features

- Lock-on switch
- Electronic variable speed
- Toolless saw blade release
- Adjustable front plate
- 3m rubber cable

Includes Hexagonal key - 2 Saw blades
Optional Accessories Reciprocating blades 9pcs RSA1001

PRECISION CIRCULAR SAW

400W CSM1038

Specifications

Mains voltage	230-240V~, 50Hz
Input power	400W
No load speed	4.200/min.
Saw blade diameter	54.8mm
Saw blade bore	11.1mm
Cutting depth	0-12mm



Features

- Laser guidance
- Adjustable sawing depth
- 4pcs saw blade set included
- 3m cable
- Storage case

Includes	Hexagonal key - Batteries for laser - Diamond blade G50 - TCT saw blade T14 - HSS saw blade T44 - HSS saw blade T60 - Dust extraction hose
Optional Accessories	Precision saw blade CSA1033 (G50) - CSA1034 (18T-TCT) - CSA1035 (44T-HSS) - CSA1037 (80T-HSS) - Dust extraction hose CSA1039

CIRCULAR SAW

1200W - 185MM CSM1039

Specifications

Mains voltage	230-240V~, 50Hz
Input power	1.200W
Bevel adjustment	0-45°
No load speed	5.000/min.
Saw blade diameter	185mm
Saw blade bore	20mm
Cutting depth max.	65mm (90°)
Cutting depth max.	43mm (45°)



Features

- Angle and depth adjustment
- Parallel guide
- Spindle lock
- 3m rubber cable

Includes	Hexagonal key - Parallel guide - TCT saw blade 185mm T24
Optional Accessories	Saw blade CSA1007 (T24)

WALL SLOTTER

1700W - 125MM WSM1009

Specifications

Mains voltage	230-240V~, 50Hz
Input power	1.700W
No load speed	4.000/min.
Cutting depth	0-28mm
Cutting width	14-19-29mm
Disc diameter	125mm



Features

- Overload protection
- Soft start
- Spindle lock
- Laser guidance
- Adjustable cutting depth and width
- 3m cable
- Storage case

Includes	2 Diamond discs - Universal vacuum cleaner adapter - Chisel - Hexagonal key - Batteries for laser
Optional Accessories	Saw blade set 2pcs WSA1001 (125mm open)

WALL SLOTTER

1600W - 150MM WSM1008

Specifications

Mains voltage	230V~, 50Hz
Input power	1.600W
No load speed	6.000/min.
Cutting depth	8-40mm
Cutting width	8-30mm
Disc diameter	150mm



Features

- Overload protection
- Soft start
- Power feedback
- Spindle lock
- Laser guidance
- Adjustable cutting depth and width
- 3m cable
- Canvas storage bag

Includes	2 Diamond discs - Universal vacuum cleaner adapter - Chisel - Batteries for laser
Optional Accessories	Saw blade set 2pcs WSA1002 (150mm open)

PAINT/CEMENT MIXER

1400W PMM1006

Specifications

Mains voltage	230V~, 50Hz
Input power	1.400W
No load speed (I)	180-380/min.
No load speed (II)	300-650/min.

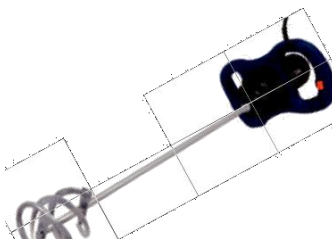

Features

- Lock-on switch
- Variable electronic speed control
- Two mechanical speed settings
- Whisk included
- 3m rubber cable

Includes	Whisk for general purposes - 2 Wrenches
Optional Accessories	Whisk PMA1004

DETAIL SANDER

220W PSM1013

Specifications

Mains voltage	230V~, 50Hz
Input power	220W
No load speed	13.000/min.
Sanding movements	26.000/min.
Sanding paper size	145x145x88mm triangle shape

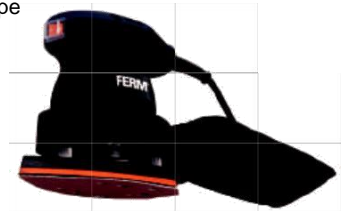

Features

- Velcro® base plate
- Active dust extraction
- 3m cable
- Storage case

Includes	5 Sanding papers (P80) - 5 Sanding papers (P120) - Dust bag
Optional Accessories	Sanding paper set 5pcs PSA1007 (P80) - PSA1008 (P120)

ORBITAL SANDER

135W PSM1027

Specifications

Mains voltage	230V~, 50Hz
Input power	135W
No load speed	13.000/min.
Sanding surface	90x187mm



Features

- Velcro® base plate
- Paper clamping system
- Universal vacuum cleaner adapter
- 3m rubber cable

Includes	Sanding paper (P80) - Vacuum cleaner adapter
Optional Accessories	Sanding paper set 10pcs PSA1035 (P60) - PSA1036 (P80) - PSA1037 (P120)

ORBITAL SANDER

180W PSM1024

Specifications

Mains voltage	230V~, 50Hz
Input power	180W
No load speed	12.000/min.
Sanding movements	24.000/min.
Sanding surface	90x187mm

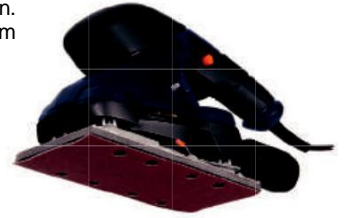

Features

- Aluminum Velcro® base plate
- Paper clamping system
- Universal vacuum cleaner adapter
- 3m cable

Includes	5 Sanding papers (P80) - 5 Sanding papers (P120) - Vacuum cleaner adapter
Optional Accessories	Sanding paper set 5pcs PSA1029 (P80) - PSA1030 (P120) - PSA1037 (P60 P80 P120)

DELTA SANDER

280W DSM1009

Specifications

Mains voltage	230-240V~, 50Hz
Input power	280W
No load speed	6.000-11.000/min.
Sanding movements	12.000-22.000/min.
Sanding surface	90x90x90mm



Features

- Velcro® base plate
- Electronic variable speed
- Universal vacuum cleaner adapter
- 3m cable

Includes	2 Sanding papers (P80 / wood) - 2 Sanding papers (P80 / paint) - 2 Sanding papers (P80 / stone) - Vacuum cleaner adapter - Protection cover for sanding pad nose
Optional Accessories	Sanding paper set 10pcs PSA1033 (P80) - PSA1034 (P120)

RANDOM ORBITAL SANDER

430W ESM1010

Specifications

Mains voltage	230-240V~, 50Hz
Input power	430W
No load speed	5.000-13.000/min.
Base plate diameter	125mm



Features

- Velcro® base plate
- Electronic variable speed
- 3m cable

Includes	Dust collection box - 2 Sanding papers (P60) - 2 Sanding papers (P80) - 2 Sanding papers (P120)
Optional Accessories	Sanding paper set 5pcs PSA1018 (P60) - PSA1019 (P80) - PSA1020 (P120)

PRECISION BELT SANDER

400W EFM1001

Specifications

Mains voltage	230-240V~, 50Hz
Input power	400W
No load speed	1.070-1.650/min.
Belt length	455mm
Belt width	8 and 13mm



Features

- Electronic variable speed
- Quick release belt exchange
- 3m cable
- Storage case

Includes	Dust bag - Vacuum cleaner adapter - 3 Sanding arm (8mm, 13mm, 13mm angled) - 12 Sanding papers
Optional Accessories	Sanding belt set 8pcs P40, P80, P120 EFA1003 (10mm) - EFA1004 (13mm)

BELT SANDER

950W BSM1024

Specifications

Mains voltage	230V~, 50Hz
Input power	950W
Belt dimension	75x533mm
Sanding surface	75x135mm
Belt speed	380m/min.



Features

- Electronic variable speed
- Quick release belt exchange
- 3m cable

Includes	Sanding belt (P80) - Dust bag
Optional Accessories	Sanding belt set 3pcs P60, P80, P120 (BSA1013)

BELT SANDER

950W BSM1021

Specifications

Mains voltage	230V~, 50Hz
Input power	950W
Belt dimension	76x533mm
Sanding surface	76x135mm
Belt speed	220-350m/min.



Features

- Dual function for both manual and stationary use
- Electronic variable speed
- Quick release belt exchange
- 3m cable

Includes Dust bag - Sanding paper (P60) - Sanding paper (P80) - Sanding paper (P120) - 2 Stationary clamps - Rubber sheet
Optional Accessories Sanding belt set 3pcs P60, P80, P120 (BSA1013)

PLANER

650W PPM1010

Specifications

Mains voltage	230V~, 50Hz
Input power	650W
No load speed	16.500/min.
Max. planing width	82mm
Max. planing depth max	2mm



Features

- Lock-on switch
- Adjustable planing depth
- Reversible hard metal planing knives
- 3m cable

Includes Parallel guide - Spare belt - Dust bag
Optional Accessories Chisel set 2pcs 82mm PPA1003

PRECISION ROUTER

1300W PRM1015

Specifications

Mains voltage	230V~, 50Hz
Power input	1300W
No load speed	9.000-30.000/min.
Max. cutting depth	60mm
Max. cutter diameter	30mm



Features

- Accurate depth adjustment: 0.1mm
- Electronic variable speed control
- LED work light
- Lock-on switch in handle
- Dust extraction connector
- Spindle lock
- 3m cable

Includes Parallel guide - Template guide - Wrench - Hexagonal key - 6pcs bit set - 6mm+8mm collet
Optional Accessories Router bit set 8pcs PRA1008 - Router table PRA1011

ROUTER TABLE

PRA1011

Specifications

Mains voltage	230V~, 50Hz
Table size	455x330mm
Max. base plate diameter router	162mm

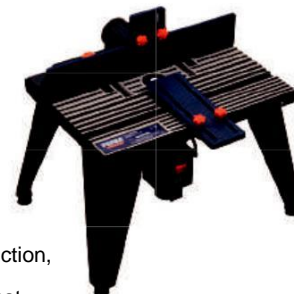

Features

- Safety switch
- Dust extraction port
- Adjustment plate
- Robust and stable aluminum construction, provided with rubber feet
- Fits all current FERM routers and most other routers

Includes Fence - Featherboard - Vacuum cleaner adapter

PRECISION BISCUIT JOINTER

900W BJM1009

Specifications

Mains voltage	230V~, 50Hz
Input power	900W
No load speed	11.000/min.
Saw blade	100x22mm
Saw blade thickness	4mm
Cutting depth	0-14mm
Base adjustment	0°-90°
Biscuits size	0-10-20



Features

- For creating precise joints and sawing parquet along walls
- Easy adjustment for angle and material thickness
- Aluminum base plate
- Spindle lock function
- Storage case

Includes Saw blade 100x22x4mm - Hexagon key - Dustbag - 50 Biscuits (#20)
Optional Accessories Biscuits 50pcs 56x23x4mm BJA1004 - Saw blade BJA1005

CORDLESS LI-ION MULTI TOOL

12V - 1.5AH OTM1006

Specifications

Mains voltage (charger)	100-240V~, 50/60Hz
Power input	12V-1.5Ah
No load speed	5.000-18.000/min.
Oscillation angle	3.0°
Charging time	3-5 hours



Features

- Cordless, Li-Ion technology
- Universal blade connection
- Electronic variable speed
- Easy blade exchange
- Soft grip
- Storage case

Includes Li-Ion battery (12V-1.5Ah) - 3 Sanding papers - Velcro® sanding base plate - HSS half round cutting blade - Plunge cutting blade - Scraping knife - Hexagon key
Optional Accessories Battery CDA1094 - Plunge cutting blade OTA1001 - Scraping knife OTA1002 - Sanding pad OTA1003 - HSS segment saw blade OTA1004 - Carbide blade OTA1005

MULTI TOOL 280W OTM1005

Specifications

Mains voltage	230V~, 50Hz
Input power	280W
No load speed	11.000-20.000/min.
Oscillating angle	2.8°



Features

- Lock-on switch
- LED work light
- Universal vacuum cleaner adapter
- Electronic variable speed
- Easy blade exchange
- 3m cable
- Storage case

Includes	Vacuum cleaner adapter - 10 Sanding papers - Velcro® sanding base plate - HSS half round cutting blade - Plunge cutting blade - Scraping knife - Carbide saw blade - Hexagon key
Optional Accessoires	Plunge cutting blade OTA1001 - Scraping knife OTA1002 - Sanding pad OTA1003 - HSS segment saw blade OTA1004 - Carbide blade OTA1005

CORDLESS LI-ION COMBITOOL 12V - 1.5AH CTM1016

Specifications

Mains voltage (charger)	100-240V~, 50/60Hz
Power input	12V-1.5Ah
No load speed	3.000-20.000/min.
Charging time	3-5 hours



Features

- Cordless, Li-Ion technology
- Electronic variable speed
- Suitable for 2.4mm and 3.2mm accessories
- Soft grip
- Spindle lock
- Storage case

Includes	1 Li-Ion battery (12V-1.5Ah) - 43 Accessories - Collet Ø2.4mm - Collet Ø3.2mm - Wrench - Charger
Optional Accessories	Battery CDA1094 - Combitool set 100pcs CTA1007 - Combitool set 40pcs CTA1008

COMBITOOL 160W CTM1012

Specifications

Mains voltage	230V~, 50Hz
Input power	160W
No load speed	15.000-35.000/min.
Collet diameter	2.4 and 3.2mm

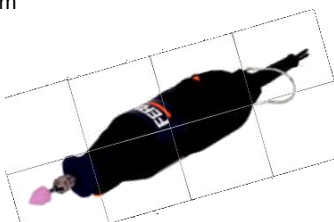

Features

- Electronic variable speed
- Spindle lock
- 3m cable
- Storage case

Includes	40 Accessories - Collet Ø2.4mm - Collet Ø3.2mm - Wrench
Optional Accessories	Combitool set 100pcs CTA1007 - Combitool set 40pcs CTA1008

COMBITOOL SET 160W CTM1010

Specifications

Mains voltage	230V~, 50Hz
Input power	160W
No load speed	15.000-35.000/min.
Collet diameter	2.4 and 3.2mm



Features

- Electronic variable speed
- Spindle lock
- 3m cable
- Flexible shaft
- Adjustable stand
- Desk stand
- Storage case

Includes	40 Accessories - Collet Ø2.4mm - Collet Ø3.2mm - Wrench
Optional Accessories	Combitool set 100pcs CTA1007 - Combitool set 40pcs CTA1008

HOT AIR GUN 2000W HAM1015

Specifications

Mains voltage	220-240V~, 50Hz
Input power	2.000W
Pos. I:	300 L/min. 450°C
Pos. II:	500 L/min. 600°C



Features

- Overheat protection
- Stationary mode
- 2 Heat and air flow settings
- 3m cable
- Storage case

Includes	Fishtail diffuser - Deflector diffuser
----------	--

CORDLESS LI-ION ELECTRIC TACKER 3.6V - 1.5AH ETM1005

Specifications

Mains voltage (charger)	100-240V~, 50/60Hz
Power input	3.6V - 1.5Ah
Staple width	11.3mm (type 530)
Staple length	6-12mm
Max. staple speed	30pcs/min.
Charging time	1 hour



Features

- Cordless, Li-Ion technology
- Max. staple size 12mm
- LED work light
- 100pcs max. capacity
- Soft grip
- USB charger
- Storage case

Includes	1000 Staples 6mm - 1000 Staples 12mm - Charger - USB charge cable
Optional Accessories	Staples 2000pcs ETA1009 (8mm)

ELECTRIC TACKER MAX. 16MM ETM1004

Specifications

Mains voltage	230V~, 50Hz
Staple width	11.3mm
Staple length	8-16mm
Nail length	15-16mm



Features

- Impact control wheel
- Anti-jam mechanism
- Compact design
- Safety switch

Includes 400 Staples 14mm - 100 nails 15mm
Optional Accessories Nails 1500pcs ETA1005 (15mm) - Staples 2000pcs ETA1009 (8mm) - Staples 2000pcs ETA1010 (14mm)

CORDLESS LI-ION GLUE GUN 7.2V - 1.5AH GGM1003

Specifications

Mains voltage (charger)	100-240V~, 50/60Hz
Power input	7.2V-1.5Ah
Runtime on 1 charge:	45min.
Charging time	1 hour
Glue stick size	Ø7mm



Features

- Cordless, Li-Ion technology
- Fast: 15s pre-heat time
- 170° C work temp.
- Automatic stop (after 5 minutes of inactivity)
- Soft grip
- Storage case

Includes 6 Glue sticks GGA1003 (7x150mm)

GLUE GUN 16W GGM1002

Specifications

Mains voltage	230V~, 50Hz
Input power	16W
Glue stick diameter	11.2mm



Features

- LED work light
- Adjustable table stand
- Changeable nozzle
- Storage case

Includes 4 Glue sticks - Nozzle round - Nozzle flat
Optional Accessories 6 Glue sticks GGA1002 (11.2x100mm)

SOLDERING SET 100W/30W SGM1001

Specifications

Mains voltage	230V~, 50Hz
Input power soldering gun	100W
Input power soldering iron	30W
Heating time soldering gun	35sec.
Heating time soldering iron	120sec.



Features

- LED work light
- Storage case

Includes Soldering clamp with magnifying glass - Solder suction tool - Stand for soldering iron - Roll of solder - Soldering paste - Terminal pin - Spare tip

SOLDERING / BLOW TORCH MAX. 1500°C SGM1006

Specifications

Runtime on single fill	35min.
Max. flame temperature	1500°C
Max. soldering temperature	500°C



Features

- For precise soldering, shrinking, hot cutting, lighting your fireplace, for kitchen use etc.
- Suitable for standard lighter gas
- Storage case

Includes Standard tip - Chisel tip - Diagonal tip - Hot blower tip - Hot knife tip - Scraper - 2 Wrenches - De-soldering sponge

MULTIPURPOSE SPRAY GUN 110W SGM1012

Specifications

Mains voltage	220-240V~, 50Hz
Input power	110W
Max flow	300ml/min.
Container	800ml



Features

- Adjustable flow control
- Easy cleaning
- Airless spray
- 3m cable

Includes Paint container - Flexible nozzle extension - Spare nozzle - Viscosity measuring cup - Cleaning pin - Ear plugs - Wrench - Piston

BENCH PILLAR DRILL

350W TDM1025

Specifications

Mains voltage	230V~, 50Hz
Input power	350W
Chuck capacity	13mm
Taper of spindle	B16
No load speed	580-850-1.220-1.650-2.650/min.

Total height	580mm
Travel of spindle	50mm
Horizontal distance chuck to column	104mm

Features

- Cast iron base for maximum stability
- Key chuck (13mm)
- Cross laser
- In height adjustable working table with two way angle adjustment from 0° to 45°
- Safety switch



Includes Chuck key - 2 Hexagonal keys - 2 Batteries (AAA)
Optional Accessories Machine vise TDA1013

BENCH GRINDER

150W - 150MM BGM1019

Specifications

Mains voltage	230V~, 50Hz
Input power	150W
Grinding stone dimensions	150x16mm
Grinding stone grain	P36 & P60
Grinding stone bore	12.7mm
No load speed	2.950/min.

Features

- Dust protected switch
- Metal base
- Mountable to work bench



Includes Grinding stones (P36 & P60) - 2 Spark arresters - 2 Work rests - Safety glasses
Optional Accessories Grinding stone 150mm BGA1053 (16mm - P36) - BGA1054 (16mm - P60)

BENCH GRINDER

250W - 150MM BGM1020

Specifications

Mains voltage	230V~, 50Hz
Input power	250W
Grinding stone dimensions	150x20mm 150x40mm
Grinding stone grain	P36 (grey) P80 (white)
Grinding stone bore	12.7mm
No load speed	2.950/min.

Features

- Dust protected switch
- Metal base
- Mountable to work bench



Includes Grinding stones (P36 & P80) - 2 Spark arresters - 2 Work rests - Safety glasses
Optional Accessories Grinding stone 150mm BGA1055 (20mm - P36) - BGA1056 (40mm - P80)

WET AND DRY GRINDER

250W BGM1021

Specifications

Mains voltage	230V~, 50Hz
Input power	250W
Grinding stone dimensions	150x20mm 200x40mm
Grinding stone grain	P36 (dry) P80 (wet)
Grinding stone bore	12.7mm(dry) 20mm (wet)

Features

- Dust protected switch
- Metal base
- Mountable to work bench

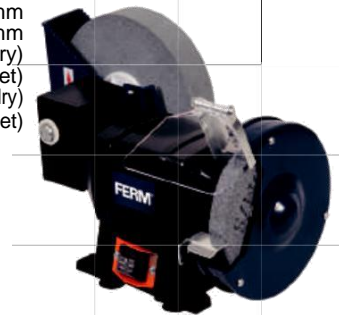

Includes Grinding stones (P36 & P80) - 2 Spark arresters - 2 Work rests - Safety glasses
Optional Accessories Grinding stone BGA1055 (150mm - 20mm - P36) - BGA1057 (200mm - 40mm - wet use)

BENCH SANDER

375W BGM1003

Specifications

Mains voltage	230V~, 50Hz
Input power	375W
Belt dimension	100x915mm
Disc diameter	150mm
Belt speed	276m/min.
Disc speed	1.450/min.
Belt position adjustable	0°-90°
Table position adjustable	0°-45°

Features

- Dust protected safety switch
- Adjustable sanding belt position
- Adjustable working table
- Quick release belt exchange
- Rubber feet



Includes 2 Sanding belts (P80, P120) - 2 Sanding discs (P80, P120) - Wrench - Mitre guide - Hexagonal key
Optional Accessories Sanding belt set 3pcs BGA1058 (P60, P80, P150) - BGA1059 (P60) - BGA1060 (P100) - Sanding disc set 10pcs BGA1036 (P60) - BGA1037 (P100) - BGA1038 (P150) - BGA1039 (P60, P100, P150)

SCROLL SAW

90W SSM1005

Specifications

Mains voltage	230V~, 50Hz
Input power	90W
Bevel adjustment table	0-45°
Max. working depth	400mm
Max. material thickness	55mm
No load speed	1.440/min.
Saw blade length	132mm

Features

- Safety switch
- Toolless saw blade release
- Transparent guard
- Working table adjustable from 0-45°
- Flexible dust blower
- Mitre/parallel guide
- Rubber feet



Includes Mitre guide - 10 Saw blades - 2 Universal saw blade adapters
Optional Accessories Scroll saw blade set 5pcs SSA1001 (15TPI) - SSA1002 (10TPI) - SSA1003 (18TPI) - SSA1004 (25TPI)

MITRE SAW

1300W - 210MM MSM1037

Specifications

Mains voltage	230-240V~, 50Hz
Power input	1.300W
No load speed	4.500/min.
Max. saw capacity	
Mitre 0°, bevel 0°	55x120mm
Mitre 0°, bevel 45°	32x120mm
Mitre 45°, bevel 0°	55x80mm
Mitre 45°, bevel 45°	32x80mm



Features

- Metal base plate
- Sliding fence
- Laser guidance
- Transparent saw blade cover
- Mountable to workbench
- Toolless mitre and bevel adjustment
- 2m cable

Includes TCT saw blade 210x30mm T48 - Hexagonal key - Dust bag - Work piece clamp - 2 Side extensions - Batteries for laser - Safety glasses - Ear plugs

Optional Accessories Saw blade 210mm MSA1024 (24T) - MSA1025 (40T)

RADIAL MITRE SAW

1900W - 210MM MSM1035

Specifications

Mains voltage	230V~, 50Hz
Power input	1.900W
No load speed	4.800/min.
Max. saw capacity	
Mitre 0°, bevel 0°	60x310mm
Mitre 0°, bevel 45°	35x310mm
Mitre 45°, bevel 0°	60x210mm
Mitre 45°, bevel 45°	35x210mm



Features

- Metal base plate
- Sliding fence
- Laser guidance
- Mountable to workbench
- Pre-settings for quick and accurate mitre-angle adjustment
- 2.5m cable

Includes TCT saw blade 210x30mm T48 - Hexagonal key - Dust bag - Work piece clamp - 2 Side extensions - Batteries for laser - Safety glasses - Ear plugs

Optional Accessories Saw blade 210mm MSA1024 (24T) - MSA1025 (40T)

RADIAL MITRE SAW

1900W - 255MM MSM1038

Specifications

Mains voltage	230V~, 50Hz
Power input	1.900W
No load speed	4.800/min.
Max. saw capacity	
Mitre 0°, bevel 0°	70x310mm
Mitre 0°, bevel 45°	40x310mm
Mitre 45°, bevel 0°	70x210mm
Mitre 45°, bevel 45°	40x210mm

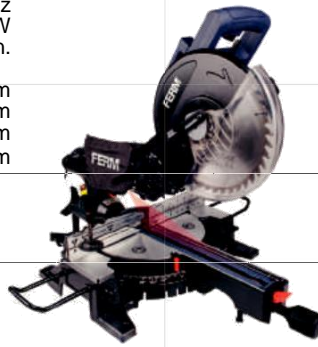

Features

- Metal base plate
- Sliding fence
- Laser guidance
- Transparent saw blade cover
- Mountable to workbench
- Pre-settings for quick and accurate mitre-angle adjustment
- 2.5m cable

Includes TCT saw blade 255x30mm T48 - Hexagonal key - Dust bag - Work piece clamp - 2 Side extensions - Batteries for laser - Safety glasses - Ear plugs

Optional Accessories Saw blade 255mm MSA1028 (40T) - MSA1029 (72T)

TABLE SAW

800W - 200MM TSM1032

Specifications

Mains voltage	230V~, 50Hz
Input power	800W
No load speed	2.950/min.
Table size	500x355mm
Saw blade diameter	200mm
Saw blade bore	16mm
Cutting capacity max.	45mm (bevel 0°)
Cutting capacity max.	27mm (bevel 45°)



Features

- Safety switch
- Induction motor
- Adjustable table 0-45°
- Mountable to workbench
- Parallel/mitre guide and clear scale
- 2m cable

Includes TCT saw blade 200x16mm T24 - Wrench - Mitre guide - Parallel guide - Push stick - Safety glasses - Ear plugs

Optional Accessories Saw blade 200mm MSA1021 (24T) - MSA1022 (40T)

TABLE SAW

1800W - 250MM TSM1033

Specifications

Mains voltage	230-240V~, 50Hz
Input power	1.800W
No load speed	4.700/min.
Saw blade adjustment	0-45°
Max. cutting capacity	0° 74mm - 45° 63mm
Saw blade diameter	250mm
Table height	865mm
Table size (fully extended)	930x625mm



Features

- Safety switch
- Overload protection
- Dust extraction
- Extendable aluminum table top
- Height adjustable saw blade
- Angle adjustable saw blade

Includes TCT saw blade 250x30mm T40 - Wrench - Hexagonal key - Mitre guide - Parallel guide - Push stick - 1 Set sliding feed - Safety glasses - Ear plugs

Optional Accessories Saw blade 250mm MSA1026 (40T) - MSA1027 (72T)

TILE CUTTER

600W - 180MM TCM1010

Specifications

Mains voltage	230V~, 50Hz
Input power	600W
No load speed	2.950/min.
Table adjustment	0-45°
Table size	360x330mm
Disc diameter	180mm
Saw blade bore	22.2mm



Features

- Safety switch
- Adjustable table from 0-45°
- Durable chrome plated table
- Parallel / mitre guide
- Low noise induction motor
- Water cooling
- Mountable to workbench

Includes Diamond saw blade 180x22.2mm - Wrench - Parallel guide - Water tray - Safety glasses - Ear plugs

Optional Accessories Diamond disc 180mm TCA1004

TILE CUTTER

900W - 200MM TCM1011

Specifications

Mains voltage	230V~, 50Hz
Input power	900W
No load speed	2.950/min.
Table adjustment	0-45°
Table size	500x400mm
Disc diameter	200mm
Saw blade bore	25.4mm



Features

- Safety switch
- Adjustable table from 0-45°
- Durable chrome plated table
- Parallel / mitre guide
- Low noise induction motor
- Water cooling
- Mountable to workbench

Includes Diamond saw blade 200x25.4mm - Wrench - Parallel guide - Water tray - Safety glasses - Ear plugs
Optional Accessories Diamond disc 200mm TCA1005

AIR COOLED GENERATOR

700W - 2HP PGM1010

Specifications

Engine power	2HP
Voltage	230V~, 50Hz
Rated output	700W
Max. output	800W
Tank capacity	4.5 Liter
Fuel	Gasoline and oil Mixture (50:1)
Sound pressure (Lwa)	60dB



Features

- 2-Stroke generator with up to 8 hours runtime on a single tank of fuel
- Overload switch
- Shock absorbing feet

Includes Spark plug socket - Driver handle - Oil cup

ARC WELDER

40 - 100A WEM1042

Specifications

Mains voltage	230V~, 50Hz
Welding current	40-100A
Electrode thickness	1.6-2.5mm
Welding cable	2.1m
Earth cable	1.5m



Features

- Current indicator
- Thermal cut-out with control lamp
- Forced cooling

Includes Welding mask - Scaling hammer/ Steel-wire brush - Quick instruction card
Optional Accessories⁰⁰; Electrodes 12pcs WEA1016 (2mm) - WEA1017 (2.6mm) - Electrodes 1kg WEA1011 (2mm) - WEA1012 (2.6mm) - Electrodes 5kg WEA1014 (2.6mm)

ARC WELDER

55 - 160A WEM1035

Specifications

Mains voltage	230/400V~, 50Hz
Welding current	400V max. 160A 230V max. 140A
Electrode thickness	2.0-4.0mm
Welding cable	2.1m
Earth cable	1.5m



Features

- Current indicator
- Thermal cut-out with control lamp
- Suitable for use with either 230V~ or 400V~
- Forced cooling

Includes Welding mask - Scaling hammer/ Steel-wire brush - Quick instruction card
Optional Accessories Electrodes 12pcs WEA1016 (2mm) - WEA1017 (2.6mm) - WEA1018 (3.2mm) - Electrodes 1kg WEA1011 (2mm) - WEA1012 (2.6mm) - WEA1013 (3.2mm) - Electrodes 5kg WEA1014 (2.6mm) - WEA1015 (3.2mm)

BATTERY CHARGER

6V / 12V BCM1021

Specifications

Mains voltage	230V~, 50Hz
Power Input	Max. 110W
Battery capacity	Min. 20Ah Max. 75Ah



Features

- Ampere meter
- 6/12V charging

Includes Set battery clamps - 10A fuse

BATTERY CHARGER

6V / 12V BCM1020

Specifications

Mains voltage	230V~, 50Hz
Power Input	Max. 400W
Fast charge	12V DC, 12A 100S 6A 180S
Normal charge	6/12V DC, 2A



Features

- Transport handle
- Fast and normal charge
- Deep cycle
- LCD display and indicator
- Reverse polarity, short circuit and overload protection
- Recharge of drained batteries

Includes Set battery clamps - 80A fuse

BOTTLE JACK

MAX. 2000KG JBM1001

Specifications

Max. lifting capacity	2.000kg
Min. height	181mm
Max. height	345mm
Spindle travel	48mm
Lifting height	116mm



Features

- Controlled release system
- Compact design
- Large lifting range
- Storage case

TROLLY JACK KIT

MAX. 2000KG TJM1008

Specifications

Max. lifting capacity	2.000kg
Min. height	135mm
Max. height	356mm
Lifting height	221mm



Features

- Solid construction with integrated safety valve against overloading
- Control release system
- Two ball bearing castors
- Carrying handle
- Storage case

PLATFORM TRUCK

MAX. 150KG TTM1027

Specifications

Max. carrying capacity	150kg
Platform dimensions	734x480mm
2 Swivel wheels	
2 Fixed wheels	



Features

- Rubber wheels
- Foldable push bar
- Large plateau

HAND TRUCK

MAX. 225KG TTM1028

Specifications

Max. carrying capacity	225kg
Size	1.130x545x430mm
Lifting plate thickness	3.5mm



Features

- Ball bearing wheels with inflatable tyres
- Stable base plate
- Steel rims

HIGH PRESSURE CLEANER

1850W GRM1013_1

Specifications

Mains voltage	230V~, 50Hz
Power input	1.850W
Max. pressure	135 bar
Max. flow	427 liter/hour



Features

- Aluminium pump
- Seperate detergent bottle
- Auto stop system
- Accessory storage facility
- 5m cable

Includes

Standard lance (on machine) - 6m Hose - Detergent bottle - Turbo lance - Fixed brush - Rotary brush

PORTABLE COMPRESSOR

1100W CRM1049

Specifications

Mains voltage	230V~, 50Hz
Power input	1.100W (S3-15%)
No load speed	3.550/min.
Air displacement	180 liter/min.



Features

- Oil free
- 3m Rubber hose with universal quick coupling
- Carrying handle with soft grip
- 5m cable

Includes

Tyre inflator with manometer - Blow gun nozzle - 3 Adapters

OIL LUBRICATED COMPRESSOR

1.1HP-750W-8L CRM1044

Specifications

Mains voltage	230V~, 50Hz
Power input	750W-1.1HP
Tank capacity	8L
No load speed	2.850/min.
Air displacement	118 liter/min.

Features

- Powerful single cylinder pump
- Pressure adjustment from 0-8 bar
- Silent direct drive induction motor
- Universal 1/4" quick coupling
- 2 Manometers for tank and outlet pressure



Includes	Oil
Optional Accessories	Air accessory set 6pcs ATA1025 Coiled hose 5m + couplings ATA1026 Air hose 10m + coupling ATA1027 Hose reel 9m ATA1033

OIL LUBRICATED COMPRESSOR

1.5HP-1100W-24L CRM1045

Specifications

Mains voltage	230V~, 50Hz
Power input	1100W-1.5HP
Tank capacity	24L
No load speed	2.850/min.
Air displacement	155 liter/min.

Features

- Powerful single cylinder pump
- Pressure adjustment from 0-8 bar
- Silent direct drive induction motor
- Universal 1/4" quick coupling
- 2 Manometers for tank and outlet pressure



Includes	Oil
Optional Accessories	Air accessory set 6pcs ATA1025 Coiled hose 5m + couplings ATA1026 Air hose 10m + coupling ATA1027 Hose reel 9m ATA1033

OIL LUBRICATED COMPRESSOR

2HP-1500W-50L CRM1046

Specifications

Mains voltage	230V~, 50Hz
Power input	1.500W-2HP
Tank capacity	50L
No load speed	2.850/min.
Air displacement	206 liter/min.

Features

- Powerful single cylinder pump
- Pressure adjustment from 0-8 bar
- Silent direct drive induction motor
- Universal 1/4" quick coupling
- 2 Manometers for tank and outlet pressure



Includes	Oil
Optional Accessories	Air accessory set 6pcs ATA1025 Coiled hose 5m + couplings ATA1026 Air hose 10m + coupling ATA1027 Hose reel 9m ATA1033

AIR TOOL SET, 5PCS

ATM1036

Specifications

Spray gun	- Operating pressure 4.5-6 bar - Container capacity 400 cc
-----------	---

Tyre inflator with pressure gauge	- Operating pressure 0-8 bar
-----------------------------------	------------------------------

Air blow gun	- Recommended pressure 2-4 bar
--------------	--------------------------------

Cleaning gun	- Recommended pressure 2-4 bar - 5m coiled hose with DIN coupler - Connection universal / DIN
--------------	---

5m Coiled hose with DIN coupler	Connection universal / DIN
---------------------------------	----------------------------



PAINT SPRAY GUN

ATM1039

Specifications

Operating pressure	4.5-6 bar
Container capacity	400 cc

With both DIN and Orion coupling



Includes	DIN coupling - Orion coupling
----------	-------------------------------

PAINT SPRAY GUN

ATM1040

Specifications

Operating pressure	4.5-6 bar
Container capacity	750 cc

With both DIN and Orion coupling



Includes	DIN coupling - Orion coupling
----------	-------------------------------

TYRE INFLATOR

ATM1041

Operating pressure

0-8 bar



Includes

DIN coupling - Orion coupling

PNEUMATIC TACKER

ATM1042

Specifications

Operating pressure

4-7 bar

Staple length

12-25mm gauge 18

Staple width

5.8mm

Staple capacity

100 pcs



AIR BLOW GUN

ATM1050

Recommended pressure

2-4 bar



Includes

Long nozzle - Short nozzle - DIN coupling - Orion coupling

Includes

Oil - 100 Staples 25mm - DIN coupling - Orion coupling - Storage case

Optional Accessories

Staples ATA1028 (1800pcs - 12mm) - ATA1029 (1300pcs - 18mm) - ATA1030 (1100pcs - 22mm) - ATA1031 (1000pcs - 25mm)

AIR NAILER 50 MM

ATM1044

Specifications

Operating pressure

7 bar

Max. nail size

1.25x1.05x50mm

Nail capacity

100pcs



Includes

Oil - 100 Nails 20mm - 100 Nails 30mm - 100 Nails 50mm - 2 Hex keys - DIN coupling - Orion coupling - Storage case

Optional Accessories

1000 Nails ATA1086 (20mm) - ATA1087 (30mm) - ATA1088 (50mm)

IMPACT WRENCH

ATM1043

Specifications

Operating pressure

6.3 bar

No load speed

7.000/min

Bolt size capacity

16mm

Max. torque

310Nm

Drive shaft

1/2" square



Includes

10 Air sockets - 5" Extension bar - Oil - HEX wrench - Nipple - Mini oiler - DIN coupling - Orion coupling - Storage case

